

CONCEPTUAL®  
FURNITURE DESIGN ■

CONCEPTUAL

■ JEROME  
GAUTHIER  
STUDIO



# ABOUT CONCEPTUAL

CONCEPTUAL FURNITURE DESIGN was founded in 2016 by office furniture specialist Pieter BEECK and upholsterer John WIJNEN. Together they shared the conviction that soft seating furniture embodies the idea that workspaces should offer comfort to their users and that it helps people to connect and to communicate.

The upholstered aspect, with all its benefits, is the storyline in all our collections which all are modular in their own way, flexible and above all complementary to each other. This encourages interaction not only between the furniture but also between the users, which helps them to be inspired, learn and create.



Mention furniture that adapts somewhere ?



With years of professional practice under his belt, creative director Jérôme Gauthier watches over the values of Conceptual Furniture Design as an organisation and in addition focuses on:

> Acousticity by using materials to optimize the sound absorption and insulation.



> Capability for the user to connect with the furniture seen as a work tool.



> Easy-care upholstery which is often removable and washable.



> Use of durable materials for longevity of the products.



> Recyclability and reusability of materials after the first product life cycle.



> Customization and personalization of our collections made possible by a wide range of environmental friendly fabrics.



While creating a soft working environment remains the essential foundation of Conceptual Furniture Design, we strive to integrate sustainable practices into every aspect of our operations, including the development of new collections. The focal points at the heart of the Chorus development were reducing components, weight and packaging while enhancing the overall comfort of the user.



## ABOUT CHORUS

The CHORUS project started in December 2021 by creative director and industrial designer Jérôme Gauthier. He was inspired by the cosiness and softness of down duvets and oversized cushions expressing the desire for comfort. Not only felt in use but also visible in design.

This was concretely translated into a new construction principle based on metal tube frames covered with an elastic bands. Finished with an upholstered cover with loose seat and back cushions.

By abandoning the traditional construction method of wooden carcasses covered with cold foam and stitched fabric, we were able not only to make major weight savings but also to create an entirely sustainable product with removable and washable covers that can easily be refurbished (new covers) or dismantled and recycled at the end of its life cycle.

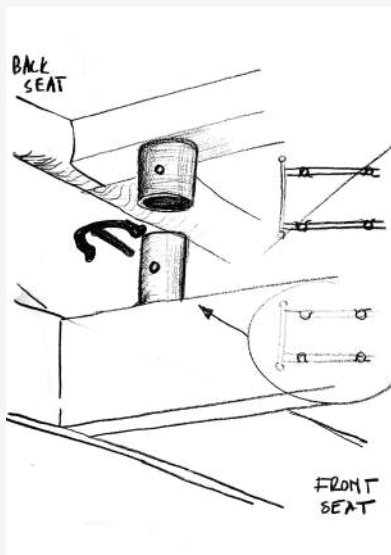

## WHY A NEW SOFT SEATING COLLECTION?



In the post Corona era, the need for flexibility in offices has taken on a new dimension. Instead of being a place where people routinely spend time, the office has now become a place to provide inspiration and strengthen cultural ties by learning, meeting clients and colleagues and stimulating creativity and innovation.

With our Clark, S-studio, Cabin and Elements collections, Conceptual already has a comprehensive range that meets those needs. Because of the weight and size of the modules however, these are less suitable for companies that need to adapt to ever-faster changes in - and outside their own organisation.

They want to use inspiring and quickly adaptable furniture elements in an agile working environment. This consideration was the starting point for the development of a new collection with the following main criteria.

- inspiring design
- visible and tangible comfort
- flexibility
- mobility
- weight saving
- durability

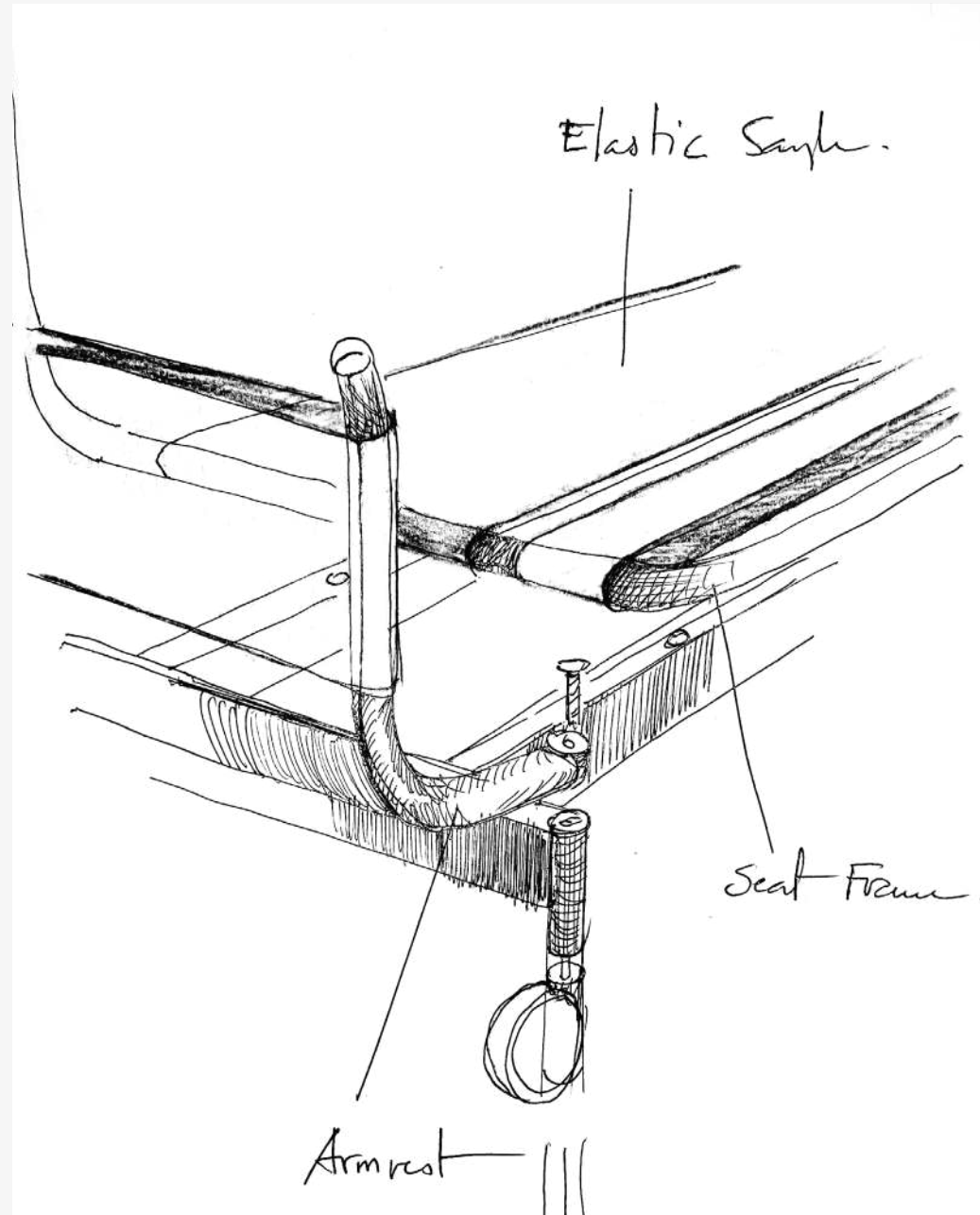



# UPHOLSTERED COVER

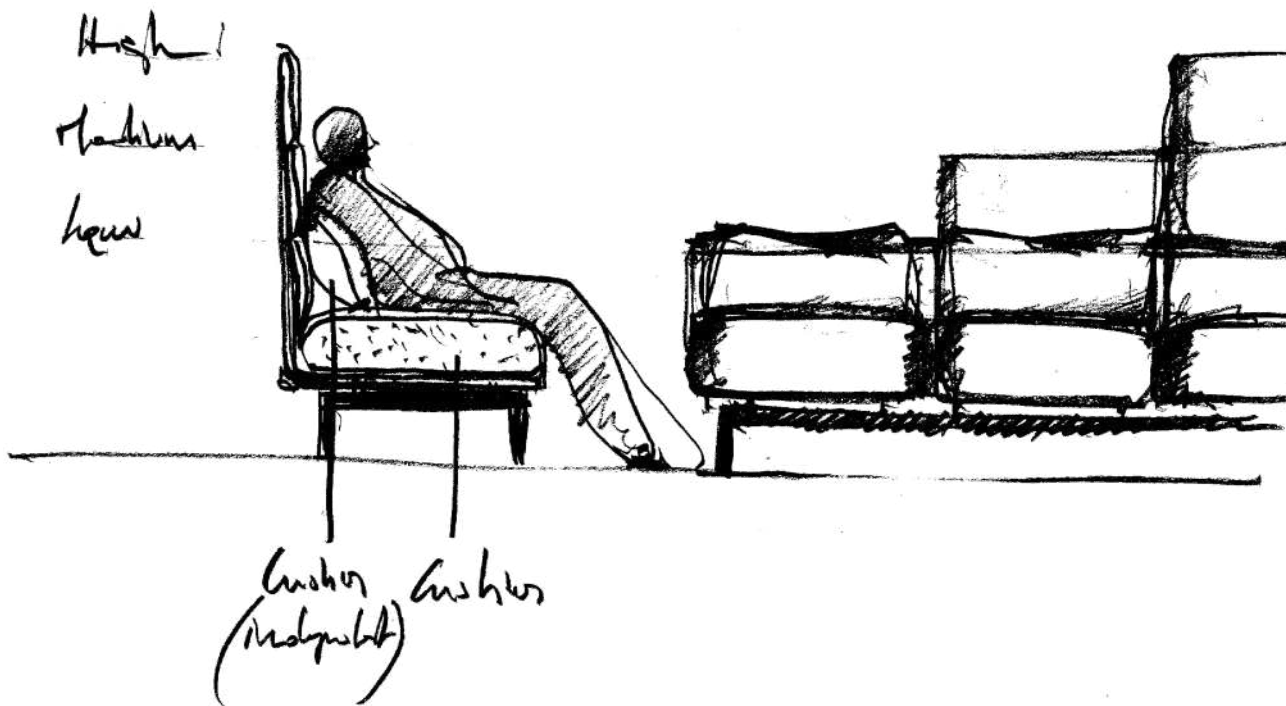
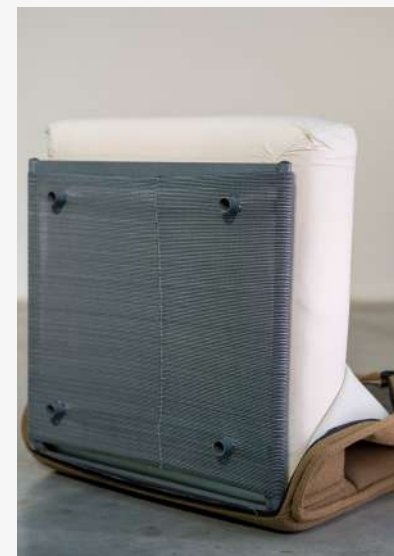
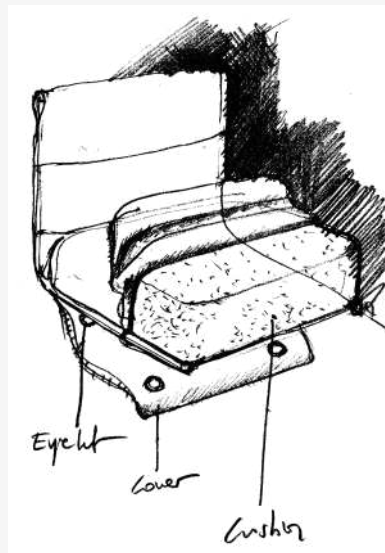

## CHORUS SOUNDS LIKE MUSIC TO THE EARS

Next to his passion for aesthetics, Jérôme Gauthier also has a passion for music.

Accompanied by his playlists during the many inspiring trips to our production facilities the name of the new collection was born CHORUS.

The contradictory double meaning of this musical term refers on the one hand to the unison singing of a group of people, but on the other hand to the constantly repeated chords around which - especially in Jazz music - improvisation takes place.

The parallel to the new Conceptual furnishing system does not come out of the blue: CHORUS invites to share while underlining the power of individual initiative within it.

Like musical notes, the new CHORUS modules can be organised and adapted into the spaces that welcome them.

We are convinced that they will inspire you to make them swing!

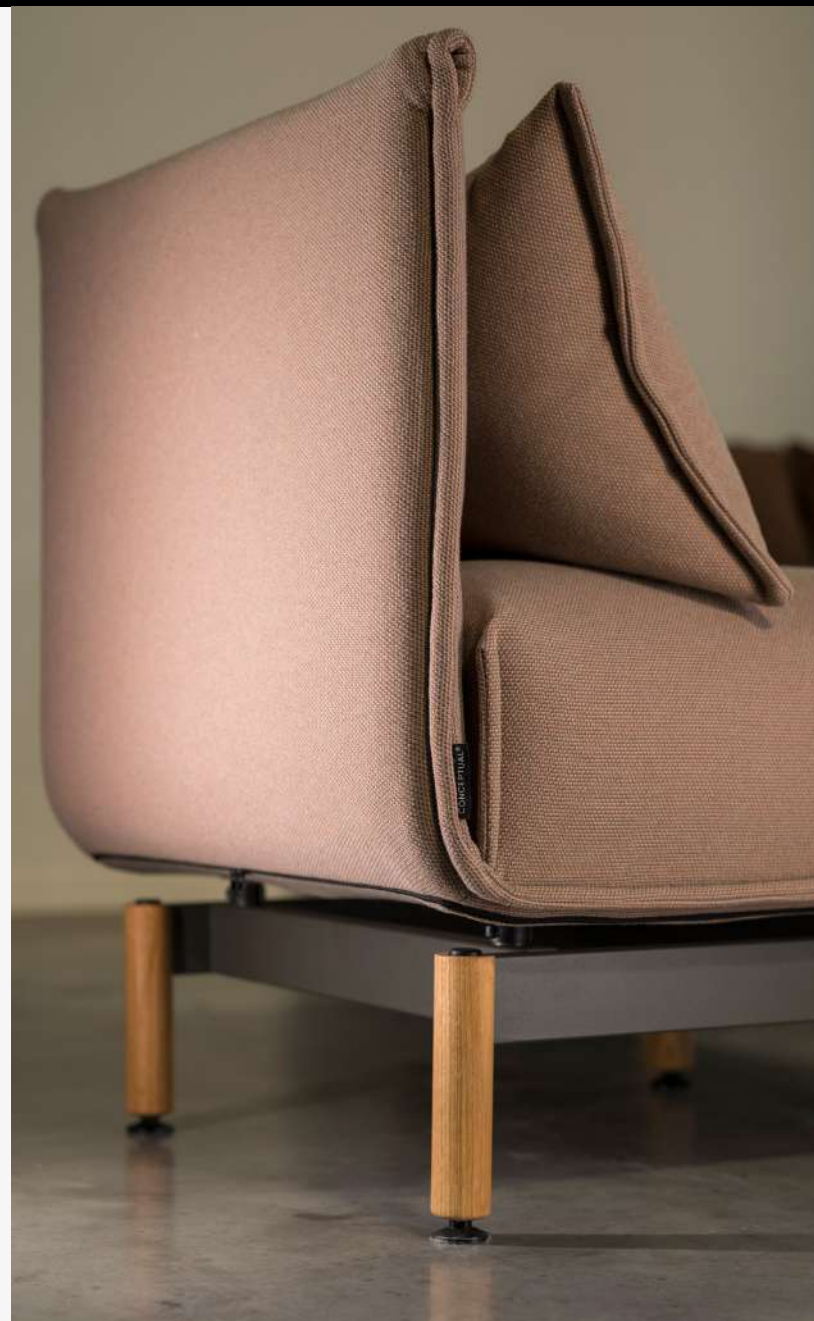
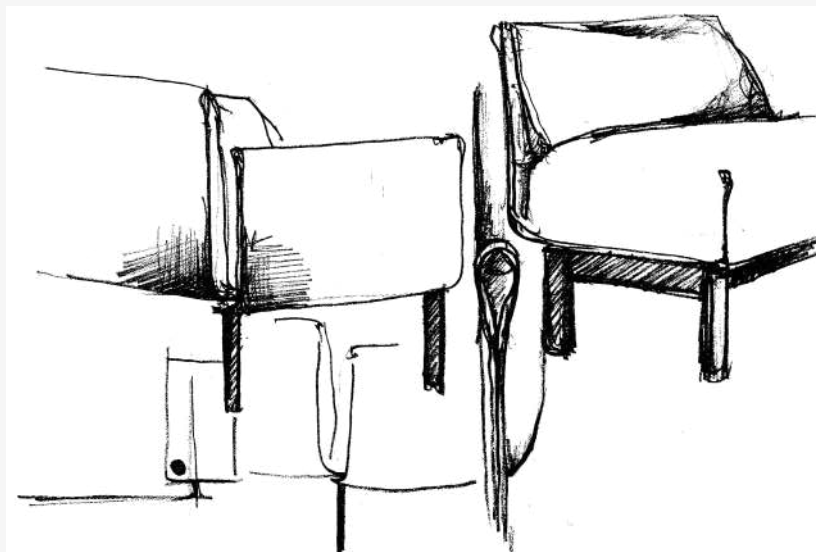

# ENDLESS POSSIBILITIES

Chorus is available in a low, medium, high back and ottoman version. Matching armrests and side panels are provided in the same height. The square 64 x 64cm seat is connected to a 1,2 or 3 seater beam set by using an ingenious tool-free clip system. In this way, an extremely flexible and modular system is created.

The collection is organised into three sub-families:

- 'Lobby' with wooden legs.
- 'Work' with metal legs without castors.
- 'Agile' with metal legs and braked castors.

It is important to note that these are not fixed components of a piece of furniture, but modules that are part of a furnishing system that can be reconfigured at will according to the user's ever-changing spatial needs.

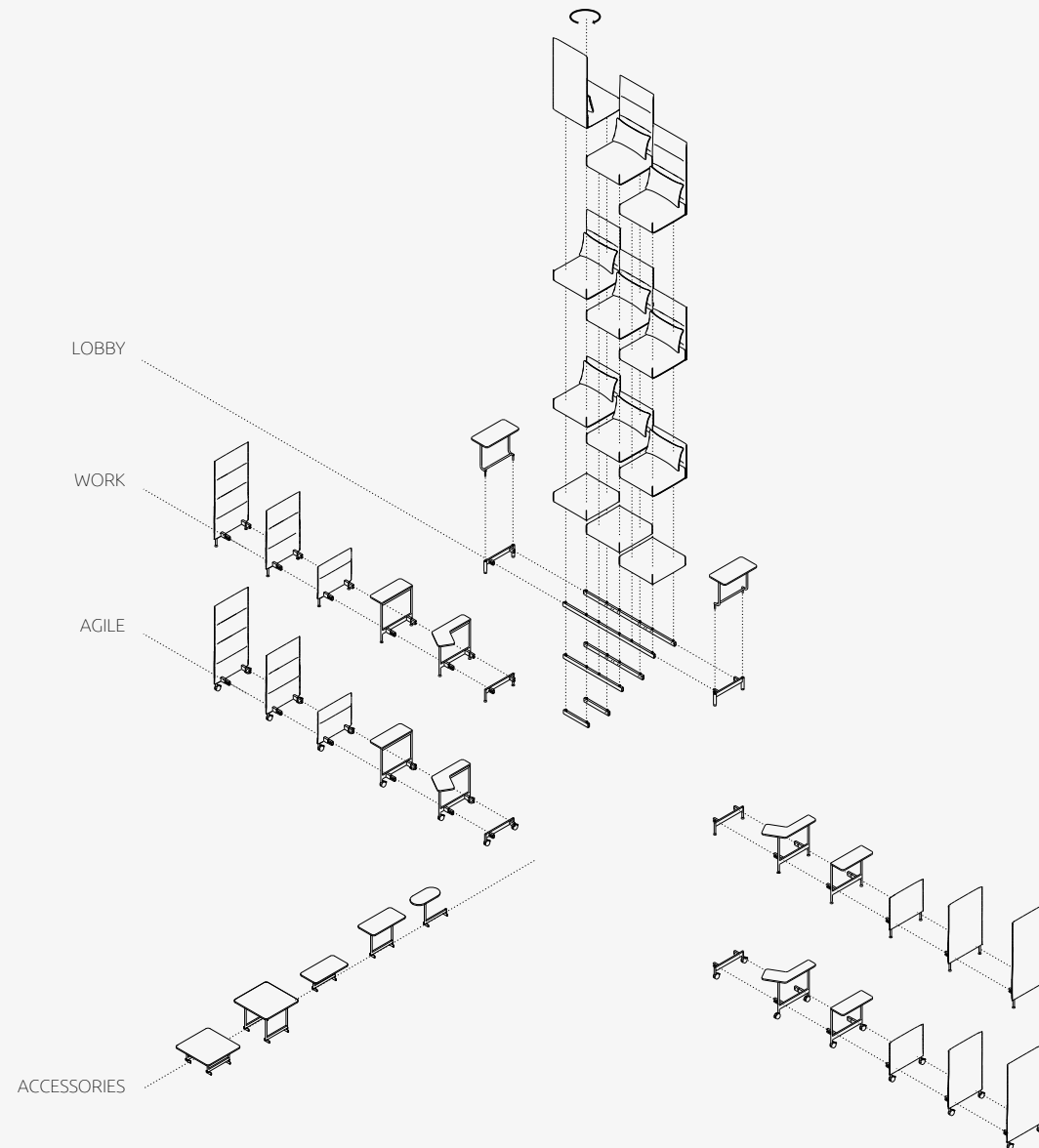



# U-LINK

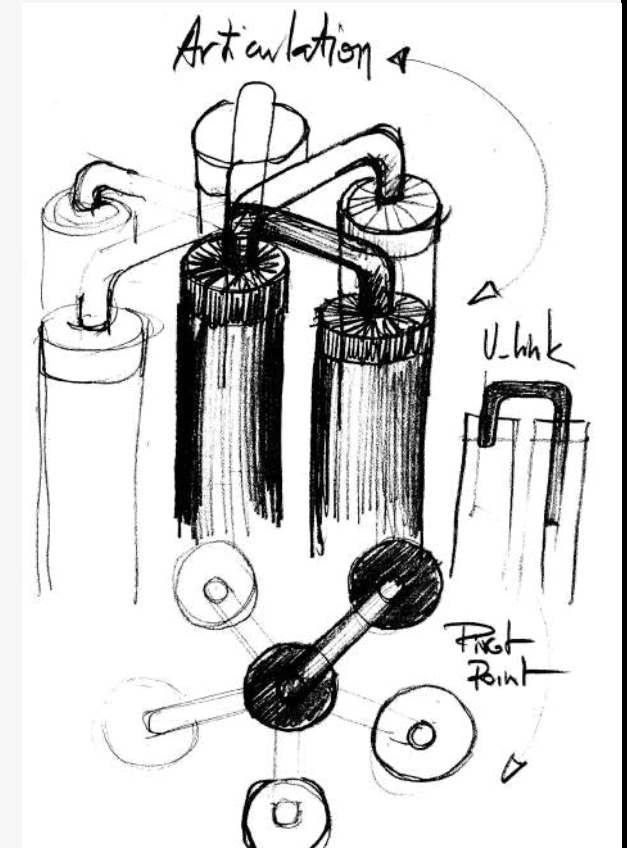
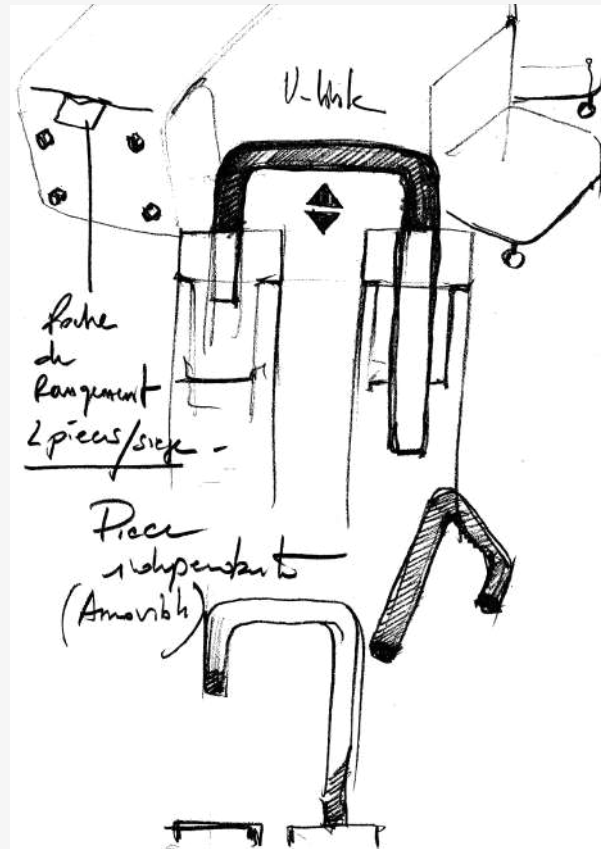





LOBBY \_ P.10

WORK \_ P.17



AGILE \_ P.23



CHORUS  
ACCESSORIES \_ P.34



CHORUS  
PODS &  
TABLES \_ P.37

# LOBBY IN ACTION

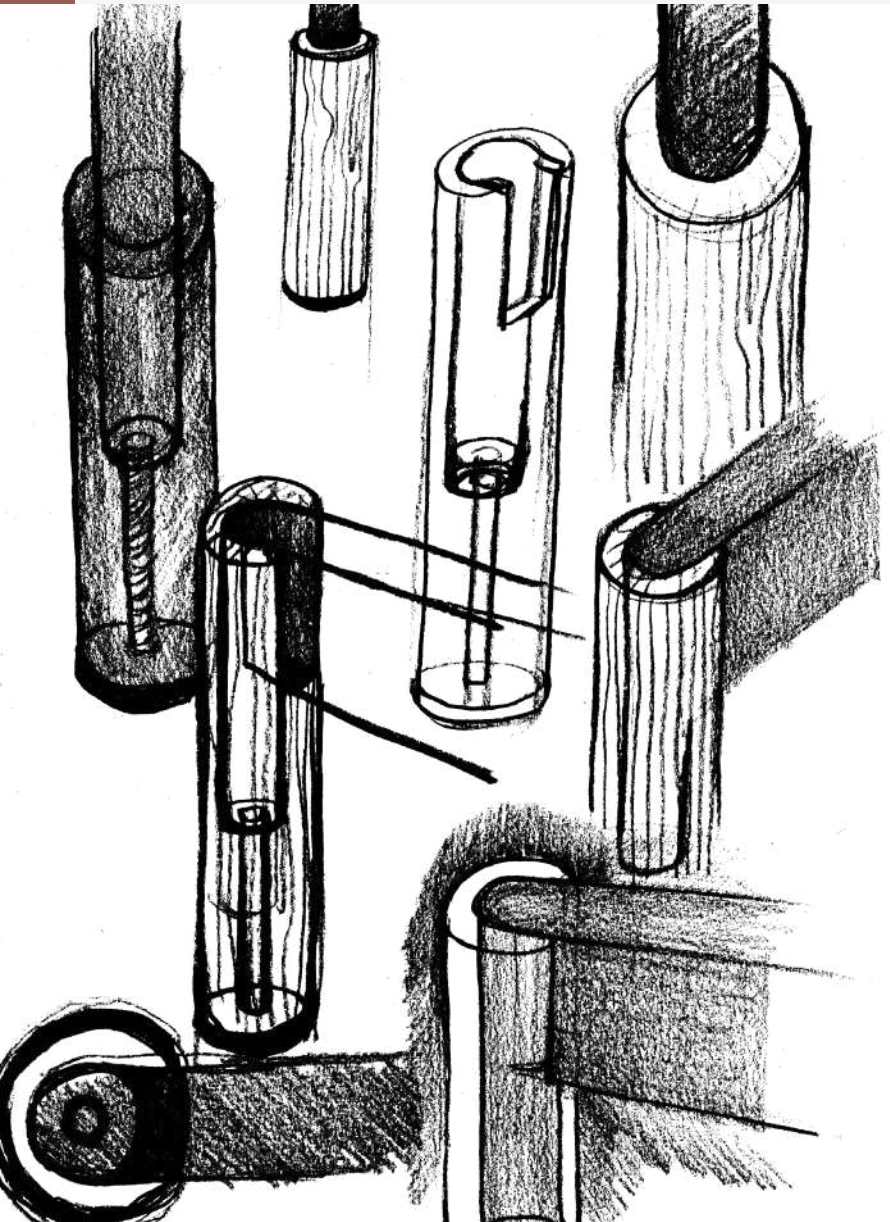
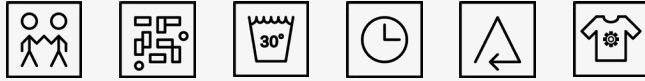



# LOBBY IN ACTION

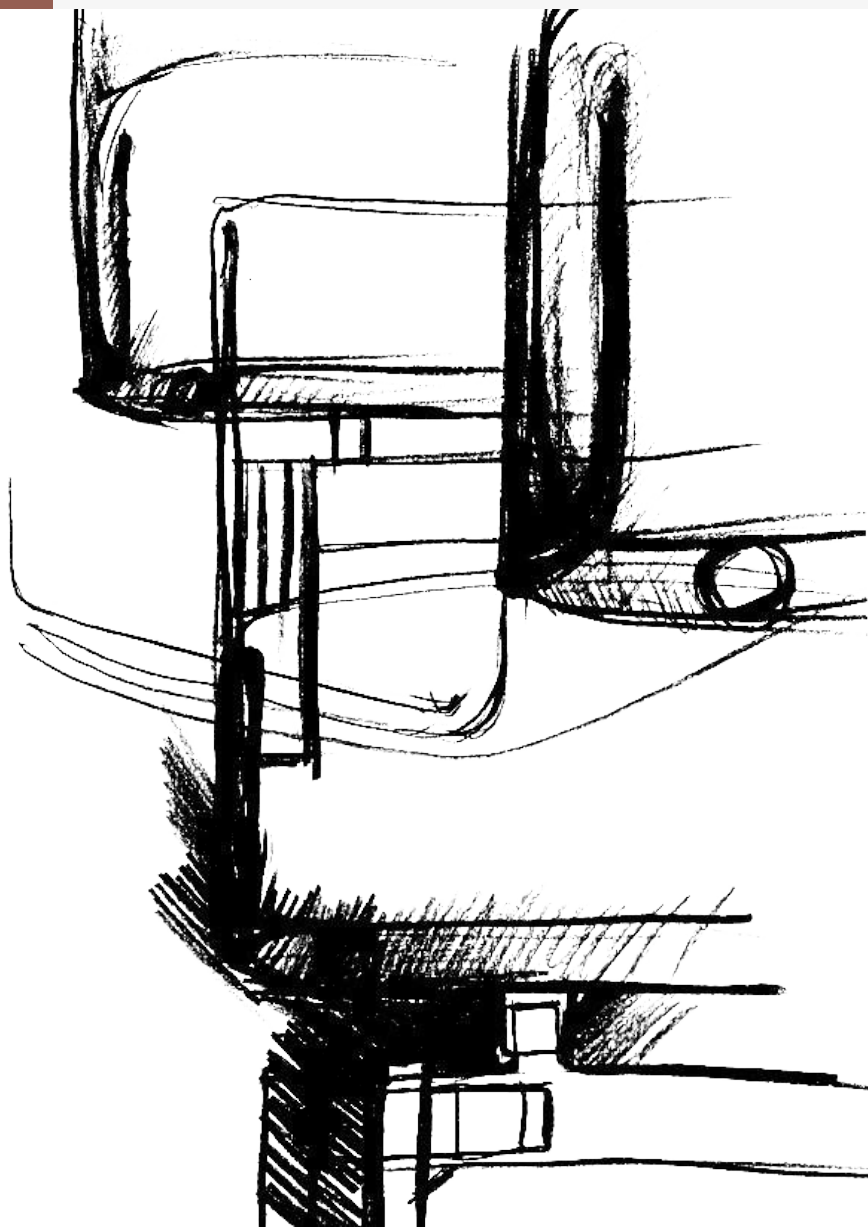

# LOBBY





# LOBBY

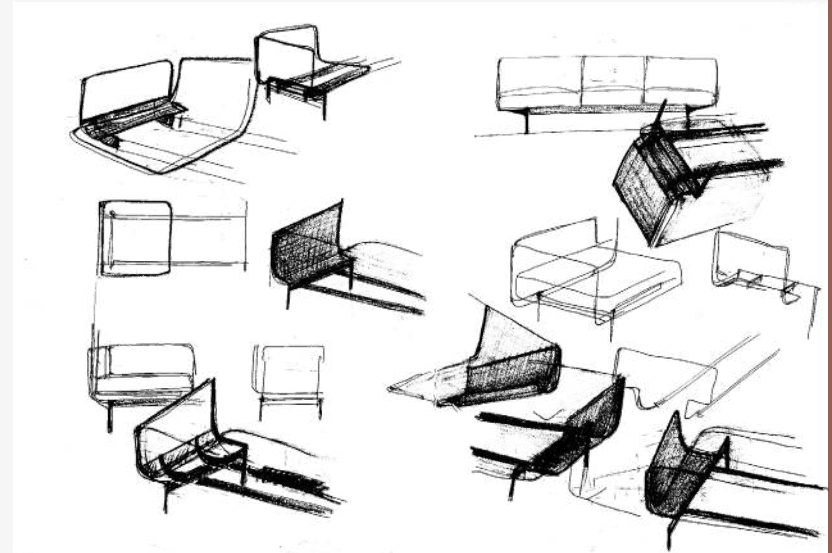
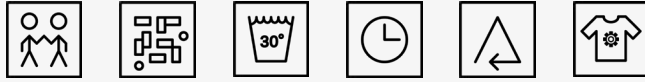

# LOBBY

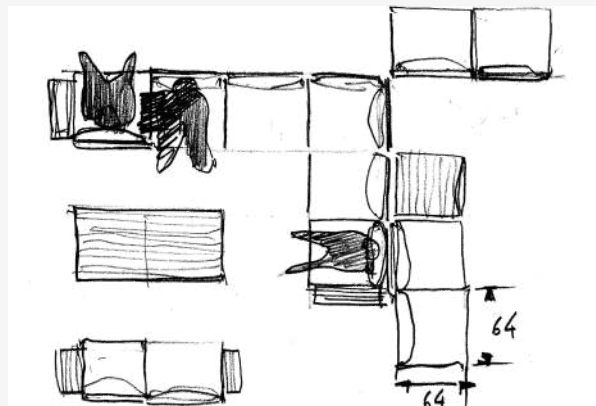

# LOBBY

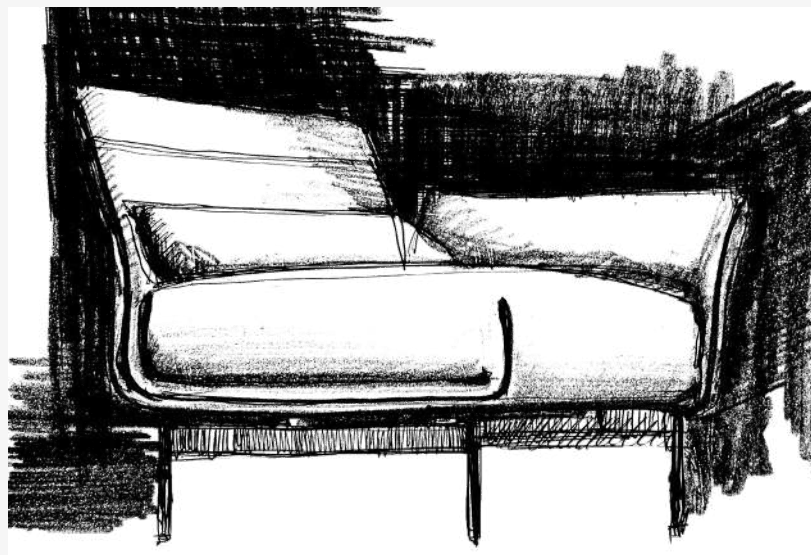
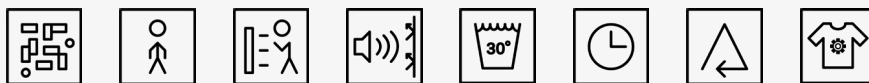



# LOBBY IN SITU

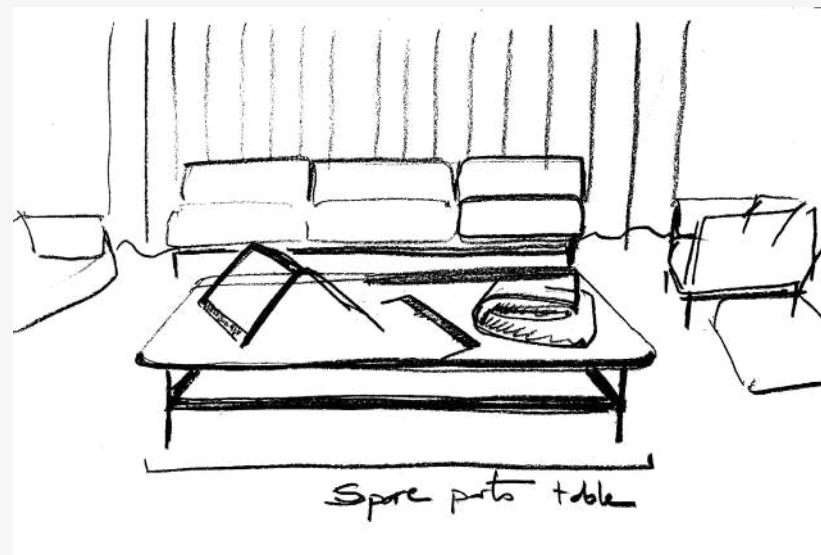



# WORK IN ACTION

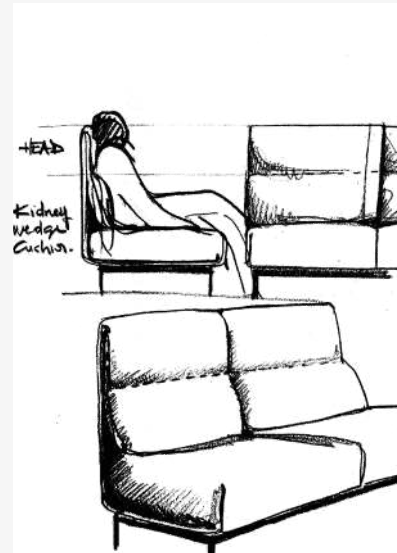

# WORK IN ACTION

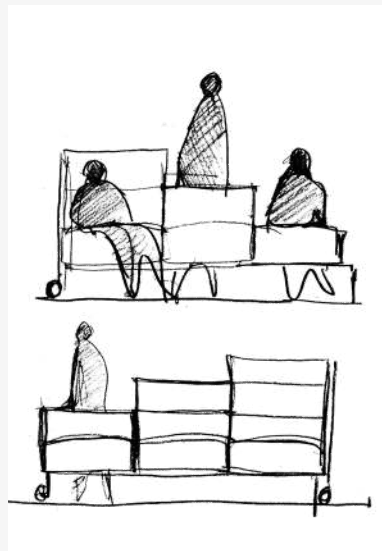
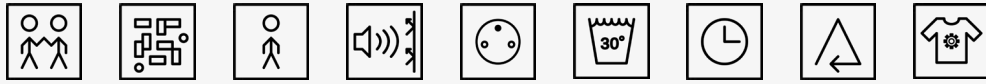

# WORK

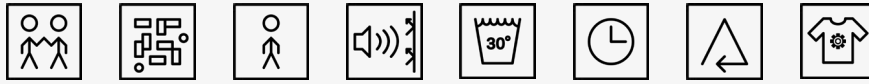

# WORK

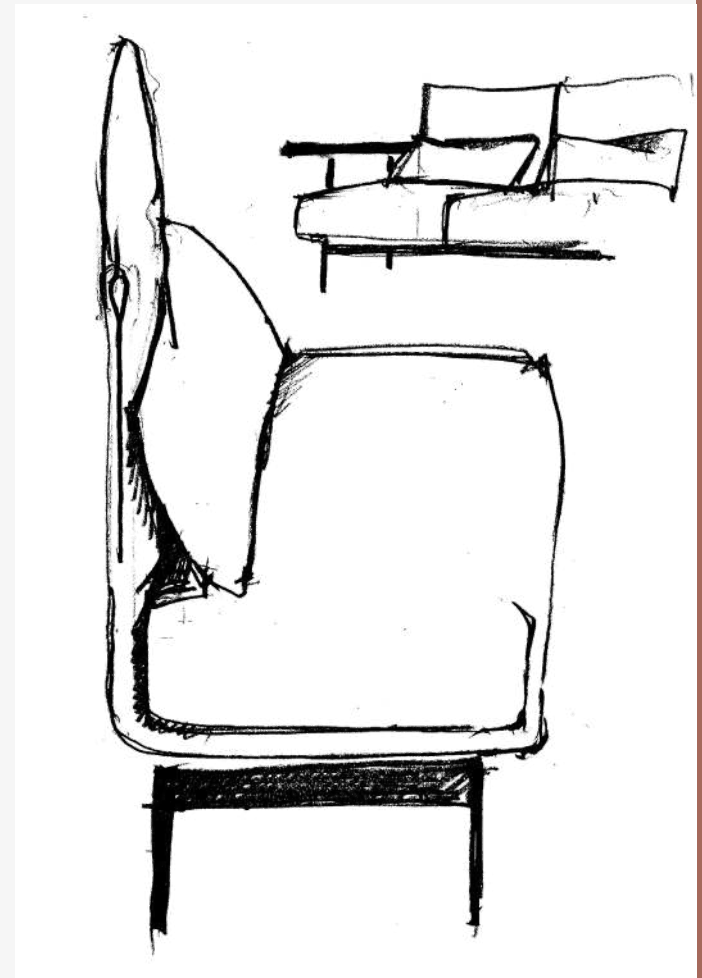



# WORK

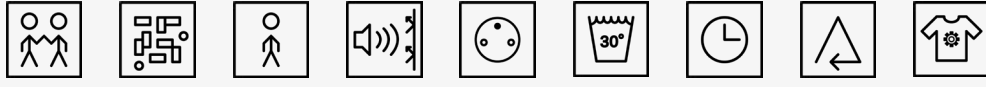

# WORK IN SITU

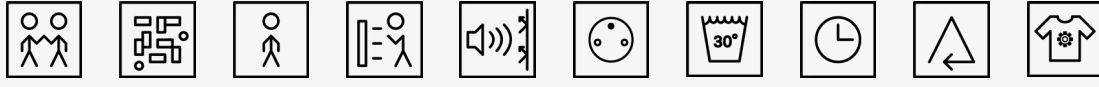

# AGILE IN ACTION

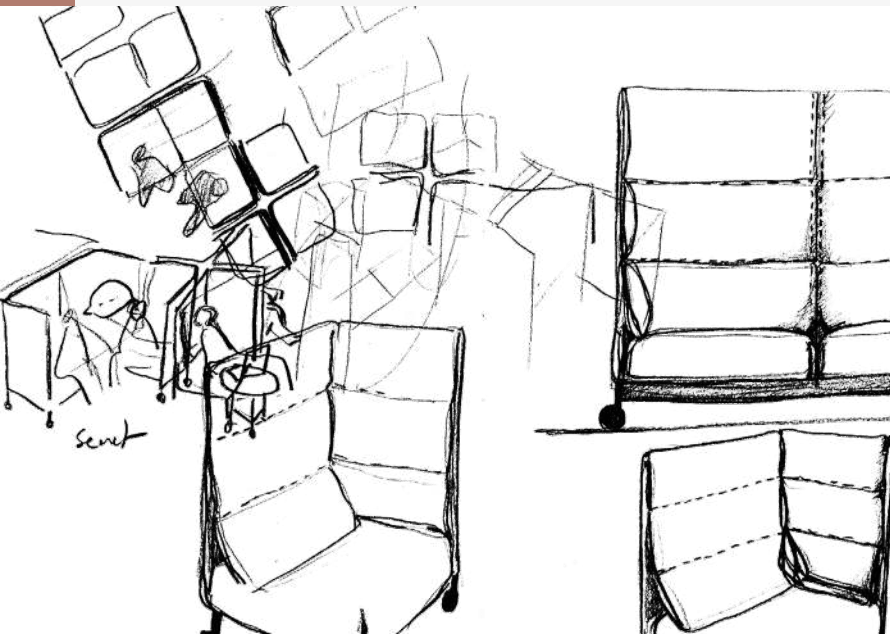
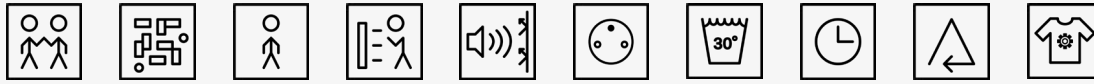



# AGILE IN ACTION

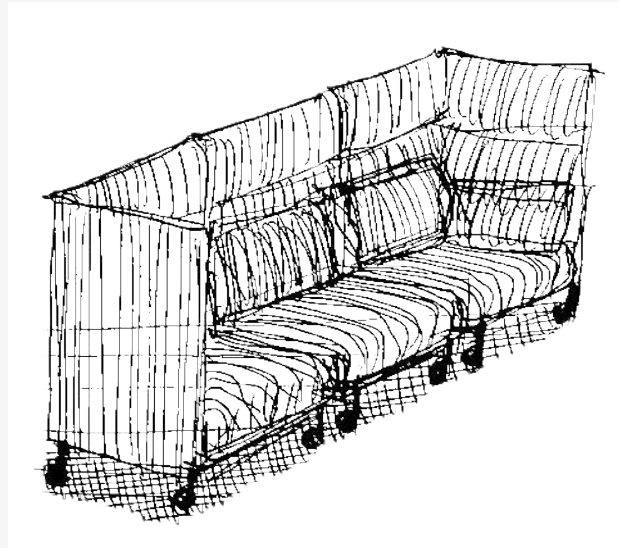

# AGILE

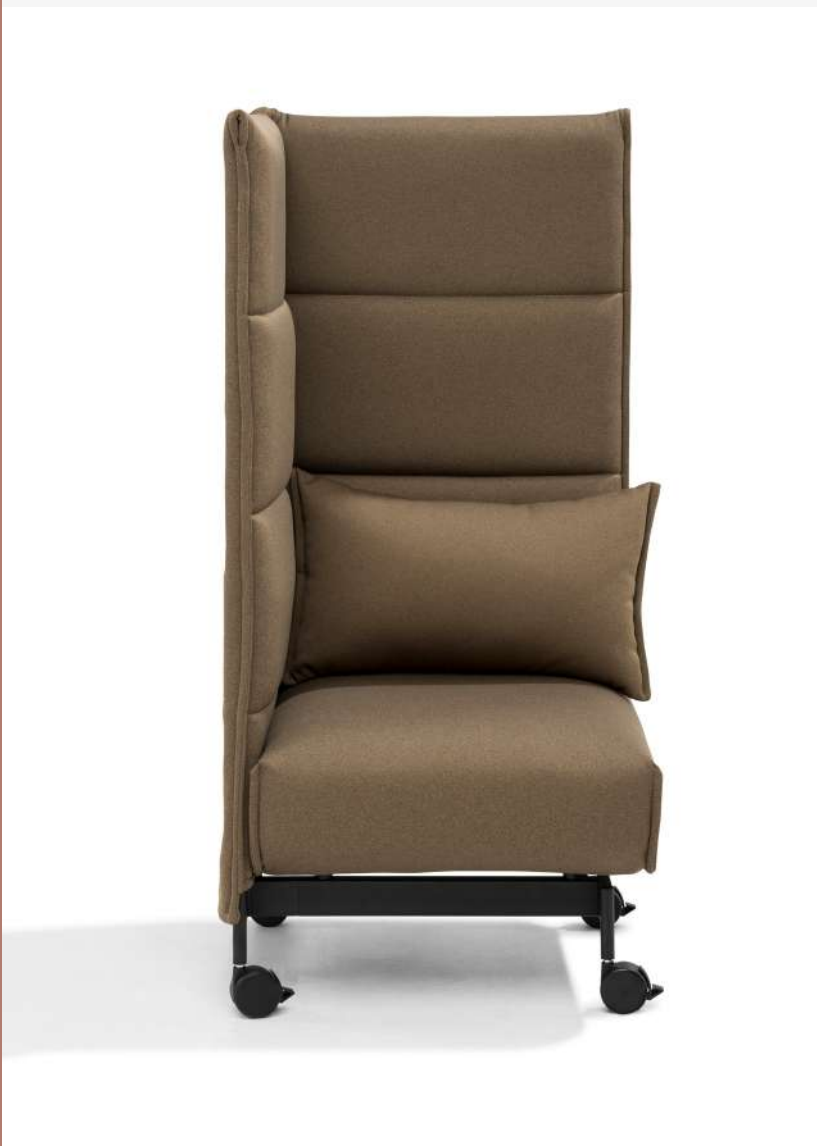

# AGILE

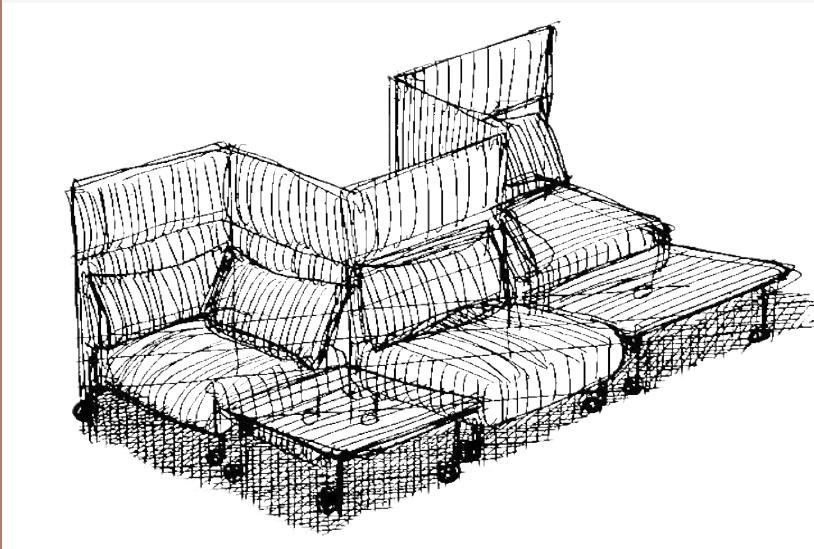



# AGILE



# AGILE

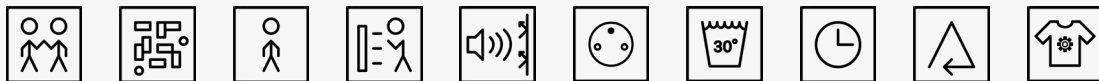

# AGILE

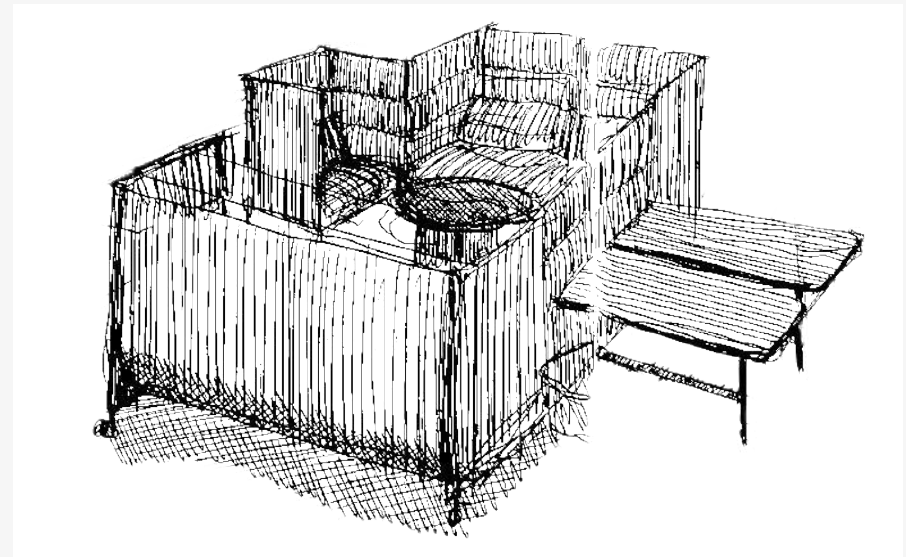
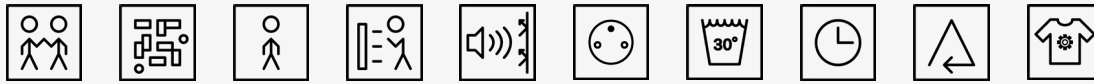



# AGILE



# AGILE



# AGILE IN SITU

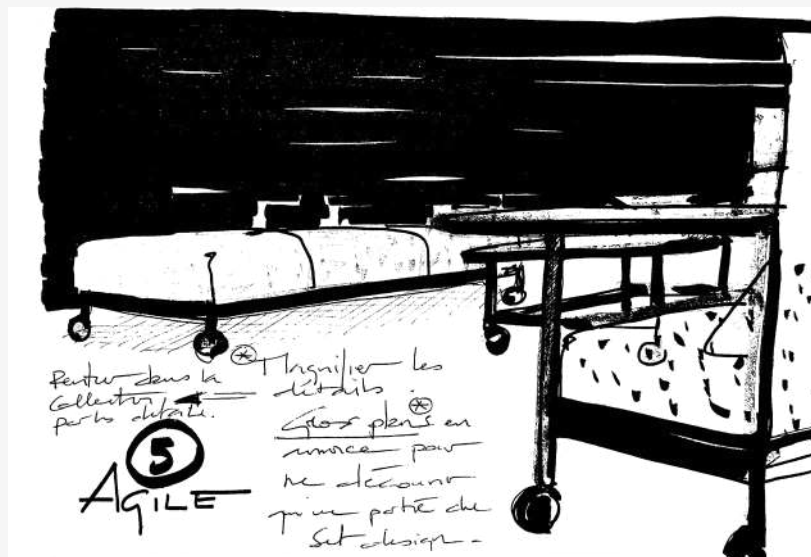
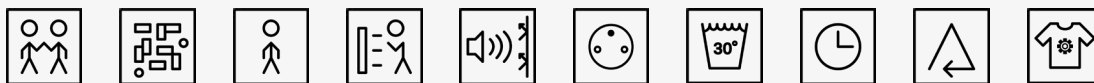



# AGILE IN SITU

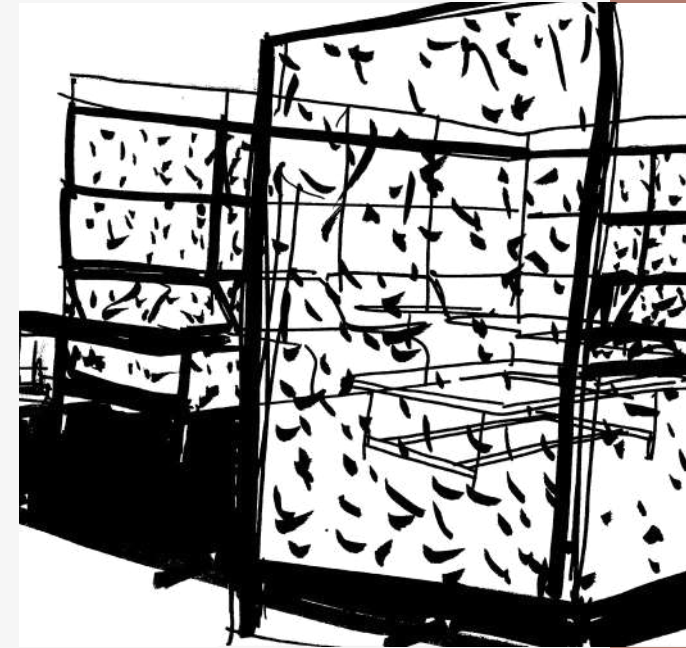

## CHORUS ACCESSORIES

Many furniture systems currently on the market make use of integrated power sockets into the seat or the armrest of the seating unit. As a result, both the flexibility and the aesthetics of the furniture suffer. For this reason, we have designed a mobile module for cable management which accompanies the user in his tasks, inspired by the idea of the Walkman. This module is upholstered in harmony with the other Chorus modules and features a compact work surface, a power unit with USB and a power cord roll-up facility.

The mobile meeting tables result from the desire for flexibility and versatility. They can be transformed into acoustic pods in no time at all.

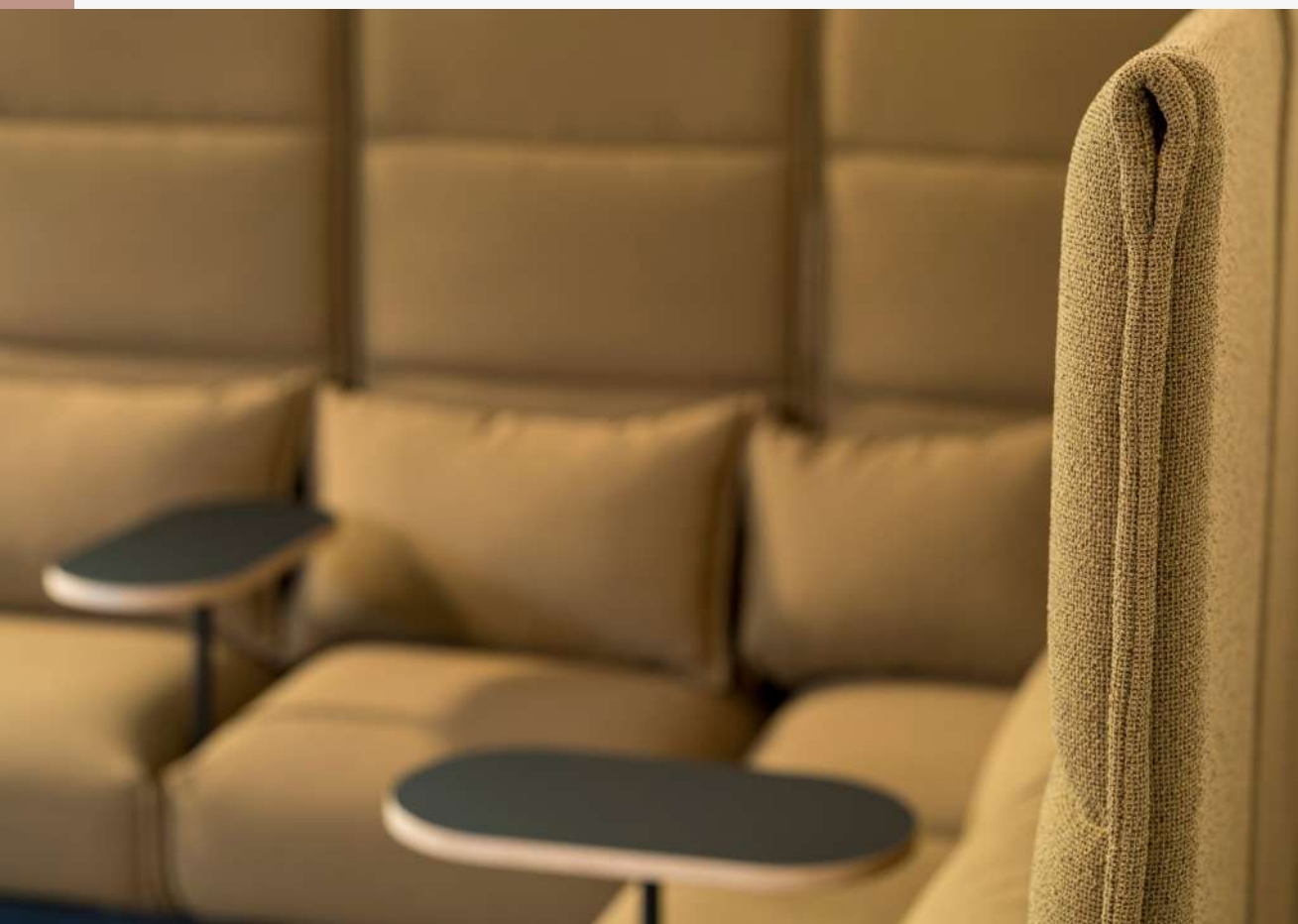
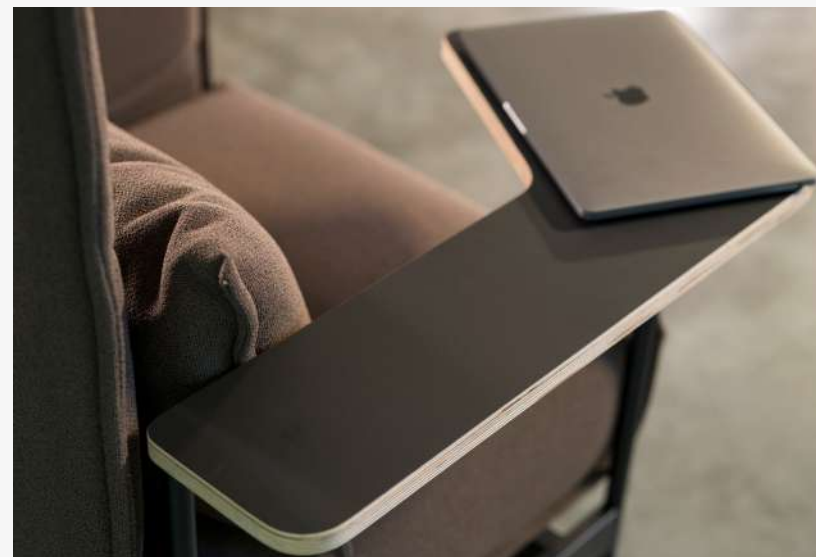
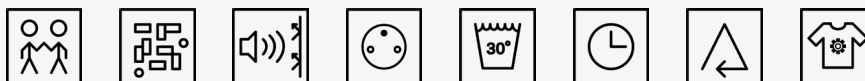

# CHORUS ACCESSORIES

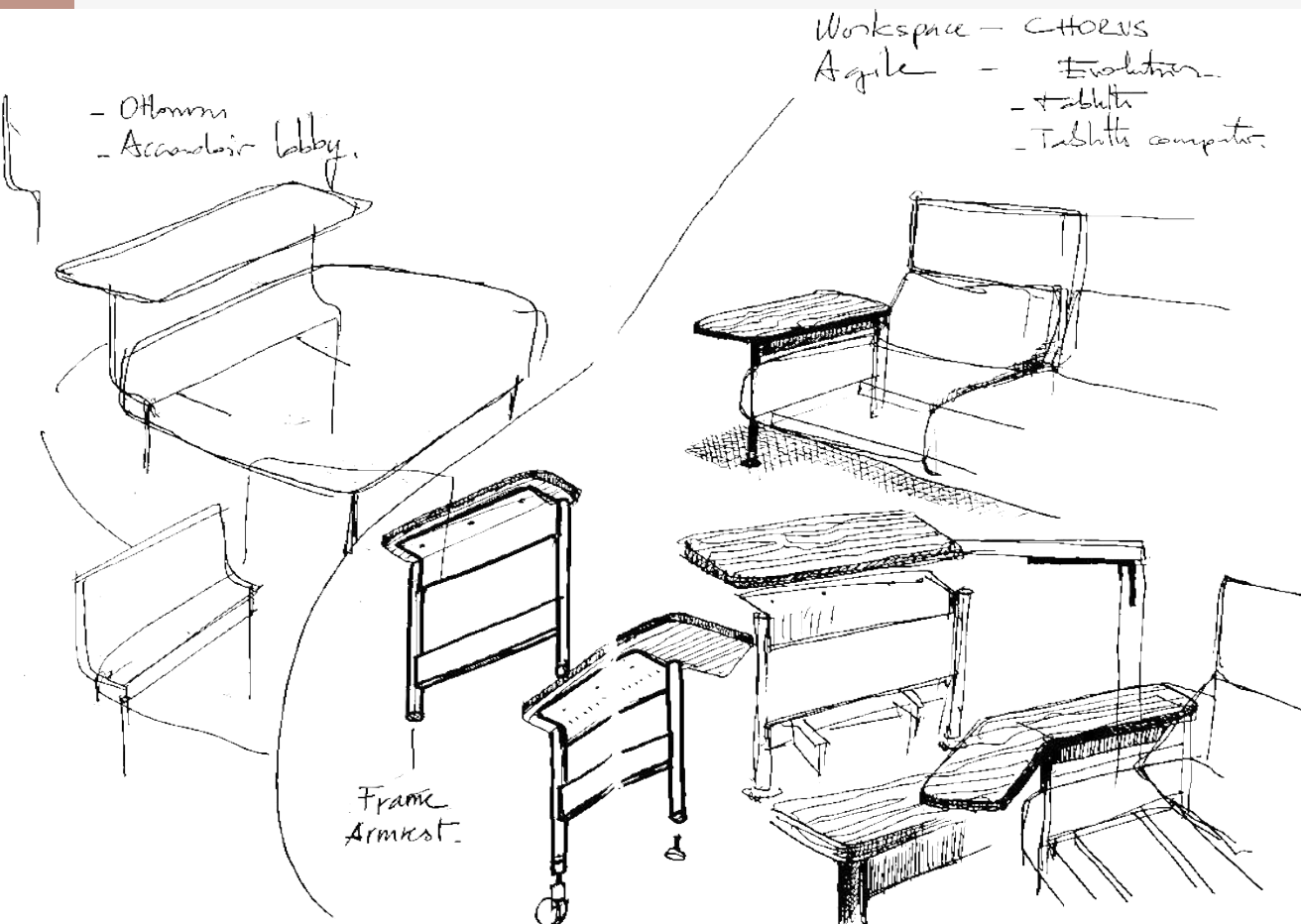



# CHORUS ACCESSORIES

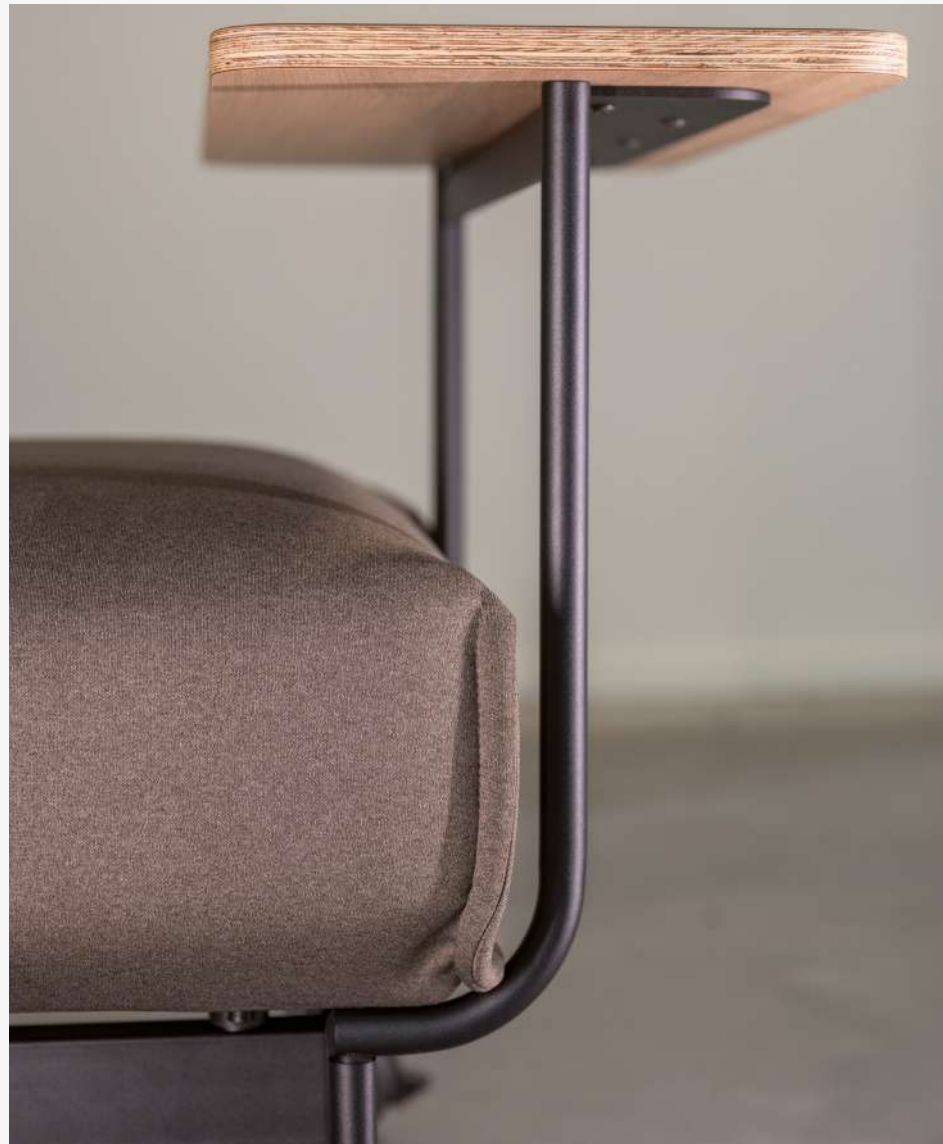
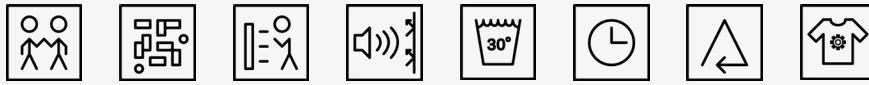



# ELECTRO SERVING TABLE

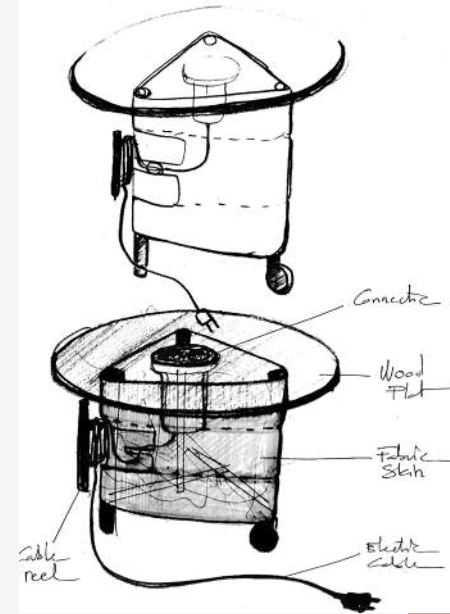
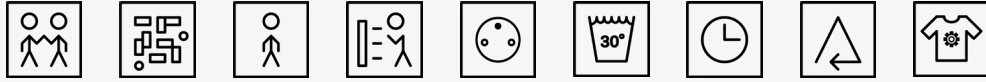

# ELECTRO SERVING TABLE

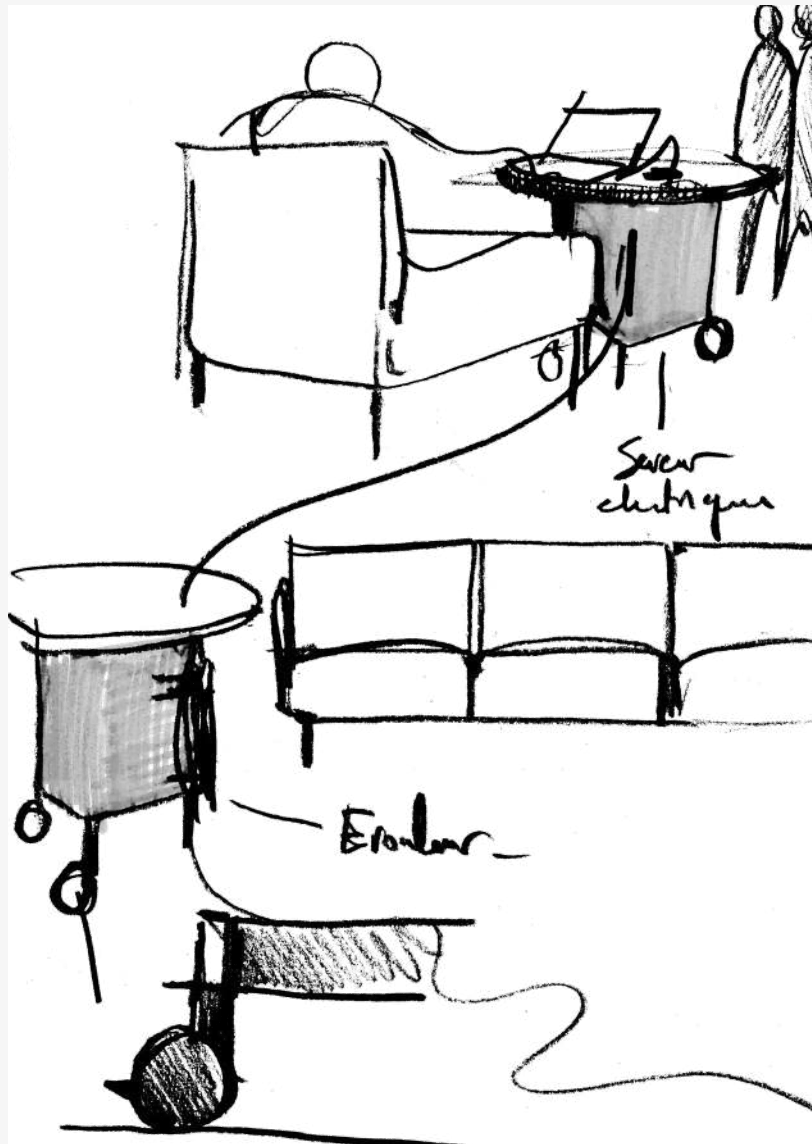
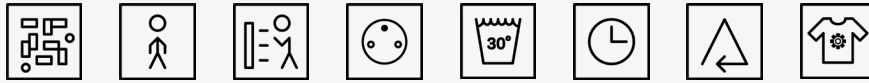

# MOBILE MEETING TABLE

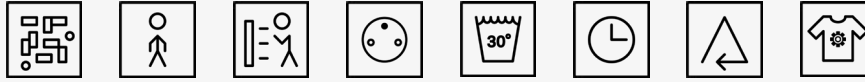



# MOBILE MEETING TABLE

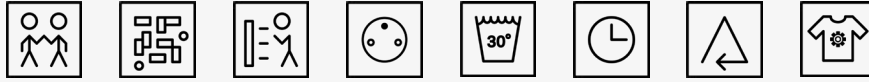



# TABLES

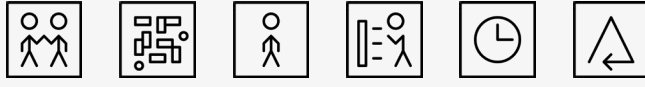

# QR CODE - FILMS

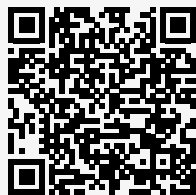

Film 1:



Film 4:

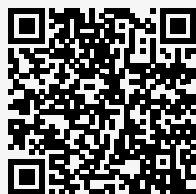

Film 2:



Film 5:



Film 3:

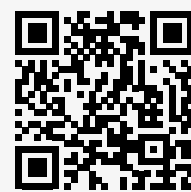

Film 6:



TO FOLLOW US



# THANKS TO

## CONCEPTUAL FURNITURE DESIGN

Casper BEECK  
Koen VERHEIJEN  
Managing partner

Pieter BEECK  
John WIJNEN  
Production & logistics

Jérôme GAUTHIER  
Creative director

Marcin BUCIUTO  
Head R&D department

Kamil KUPIS  
Product development

## BRAM DELMEE PHOTOGRAPHER

Bram DELMEE  
Photographer

Jeroen VAN DER VOORT  
First lighting assistant photographer

Harm VAN BERKEL  
Videographer

Joney HABRAKEN  
Photography assistant

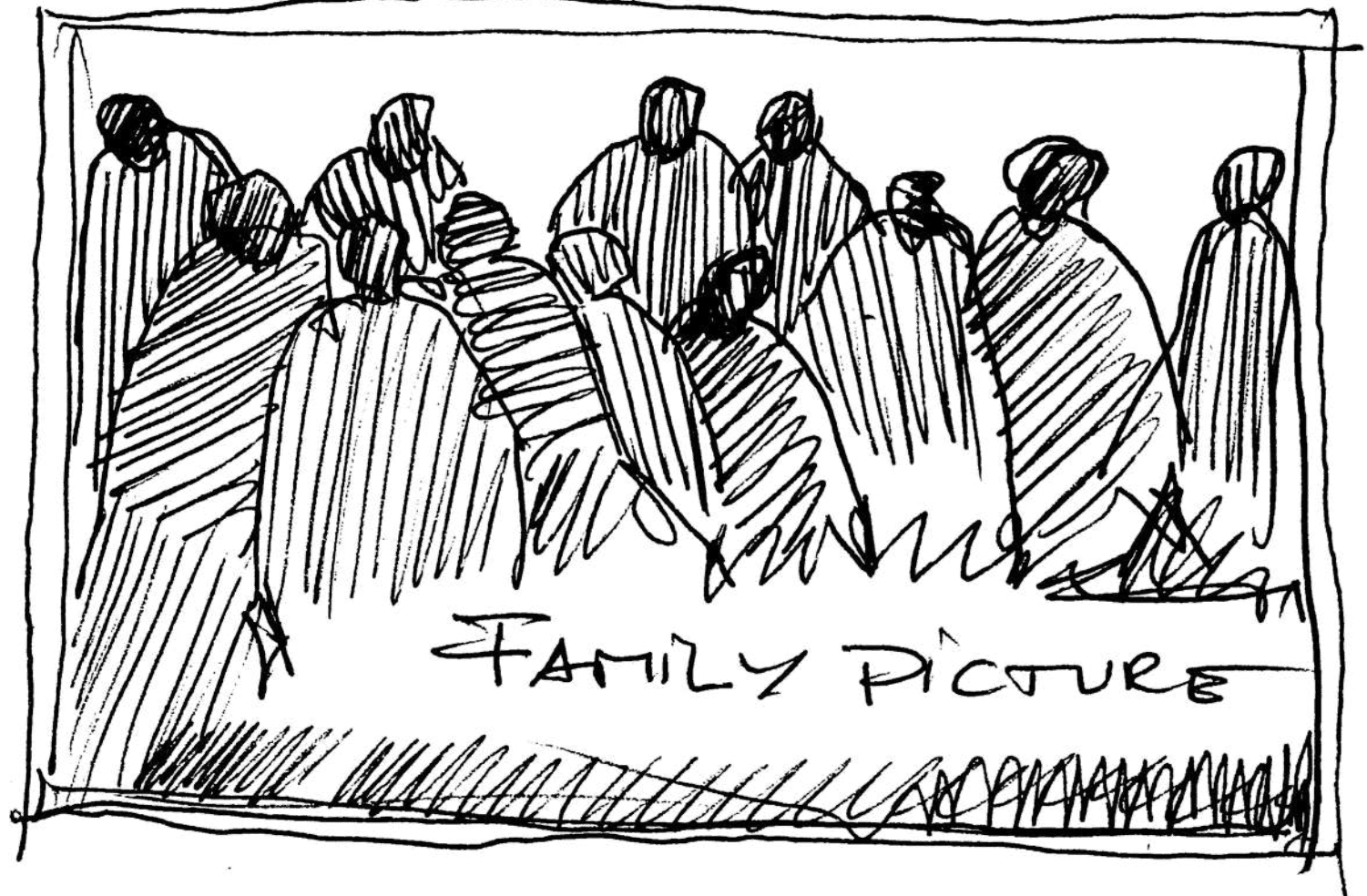

## JEROME GAUTHIER STUDIO

Jérôme GAUTHIER  
Head of the design office

Juliette NEEL  
Colors & materials

Emile GAUTHIER  
Film director

Pierre GAUTHIER  
Graphic design

Paul GAUTHIER  
3D modeling and animations

# CONTACT

## DISTRIBUTION

Conceptual works with professional dealers and agencies in different countries.

### BELGIUM / LUXEMBOURG

Concep'trade  
Klein Begijnhofbogaard 5  
2800 Mechelen  
tel +32 (0)15 33 07 25  
guy@conceptrade.be

### FRANCE & WEST SWITZERLAND

Detraz Mobilier System - DMS  
11, rue Vallon  
74200 Thonon-les-bains  
tel +33 (0)9 62 55 12 22  
v.detraz@conceptualfurniture.com

### GERMANY

Mertens AG  
Stahlwerk Becker 8  
47877 Willich  
tel +49 (0)2154 47050  
info@mertens.ag

Schwarzwald - Lab GmbH  
Siemensstraße 17  
75233 Tiefenbronn  
tel +49 (0)7234 80 6995 0  
info@schwarzwald-lab.de

### THE NETHERLANDS

SV Collection  
Weg en Bos 28  
2661 DH Bergschehoek  
tel +31 (0)10 211 2050  
info@sv.nl

Aarts & Co  
Jules Verneweg 125  
5015 BK Tilburg  
tel +31 (0)88 011 2777  
hello@aartsenco.nl

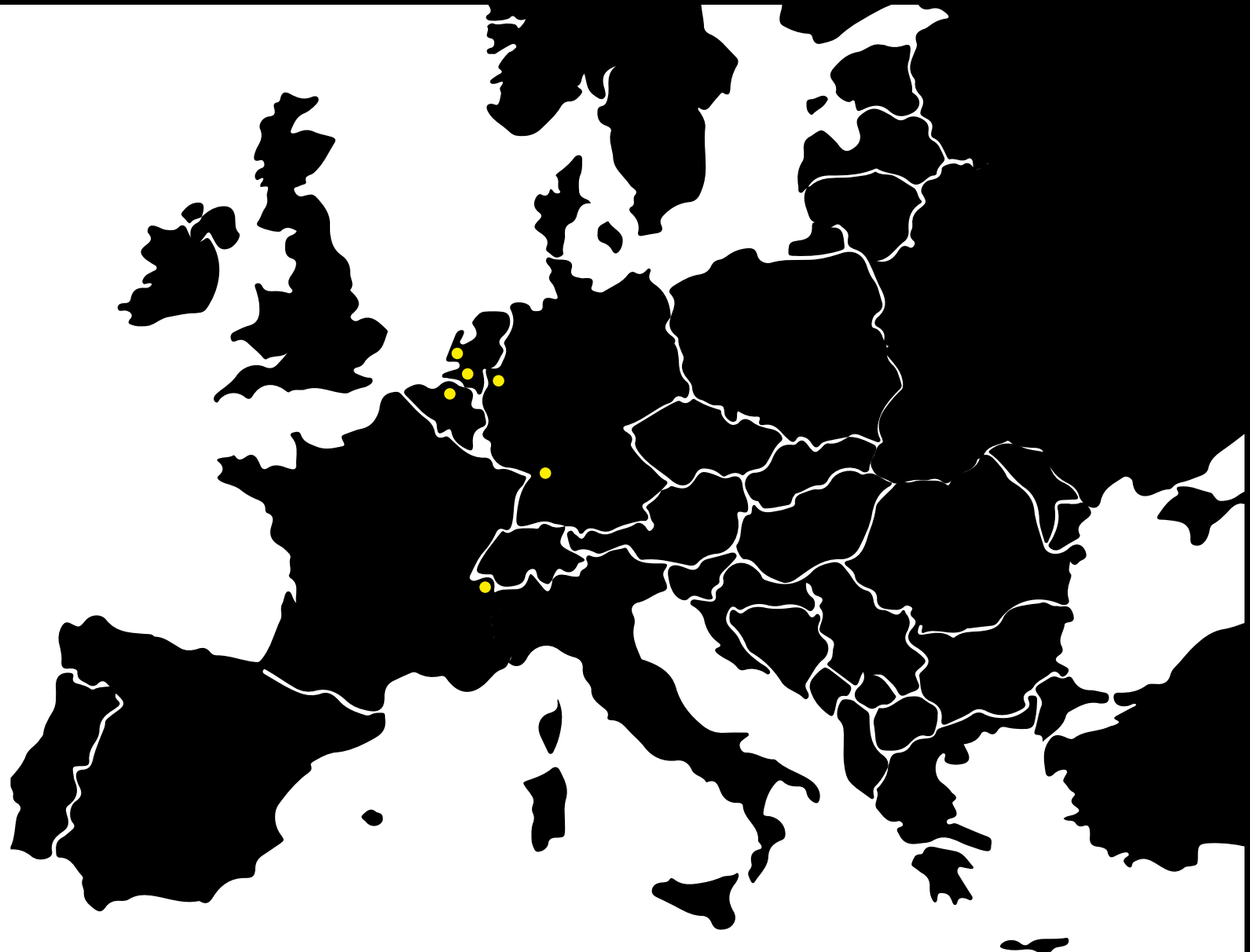

## CONCEPTUAL FURNITURE DESIGN©

Spoorlaan 436  
5038 CH Tilburg  
The Netherlands  
info@conceptualfurniture.com  
www.conceptualfurniture.com

sales support + administration tel: +31 (0)88 204 48 00





CHORUS

JEROME  
GAUTHIER  
STUDIO

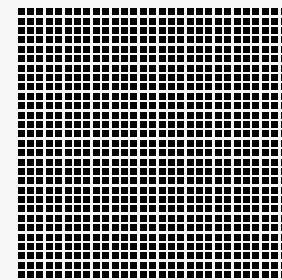

CONCEPTUAL®  
FURNITURE DESIGN